

Charlton®

STRONG-ARM



HIGH-LIFT PALLET TRUCKS

Models; HLPT550 & HLPT685

Part Nos 7630180 & 7630185

OPERATING & MAINTENANCE INSTRUCTIONS

CE

GC0511

INTRODUCTION

Thank you for purchasing this CLARKE High Lift Pallet Truck. This truck is designed to raise and lower awkward or heavy loads to an operating height where they may be handled with relative ease, avoiding the risk of injury which might otherwise occur if manhandling the load to the same height.

Before attempting to use the product, it is essential that you read this manual thoroughly and carefully follow all instructions given. In doing so you will ensure the safety of yourself and that of others around you, and you can also look forward to the product giving you long and satisfactory service.

CONTENTS

- 1 x Pallet Truck Assembly
- 1 x Handle Assembly
- 1 x Fixings Kit (3 x Screws & 3 x Spring Washers)
- 1 x Owners Manual (this document)

GUARANTEE

This CLARKE product is guaranteed against faulty manufacture for a period of 12 months from the date of purchase. Please keep your receipt as proof of purchase.

This guarantee is invalid if the product is found to have been abused or tampered with in any way, or not used for its intended purpose.

Faulty goods should be returned to their place of purchase, no product can be returned to us without prior permission.

This guarantee does not effect your statutory rights.

ENVIRONMENTAL PROTECTION



Do not dispose of this product or its packaging with general household waste. All tools, accessories and packaging contain valuable raw materials and should be sorted, taken to a recycling centre and disposed of appropriately.

To avoid pollution due to leakage, the user should provide some absorbent materials to capture any escape of oil during refilling of the hydraulic mechanism. Such materials should then be disposed of appropriately.

SAFETY PRECAUTIONS

1. Keep the work area tidy & well lit and keep children and bystanders away from the work area.
2. Never carry out any alterations or modifications to the pallet truck.
3. Do not exceed the stated capacity of the truck. Refer to the technical specifications on page 6 and the labelling on the pallet truck. Overloading may cause the truck to fail.

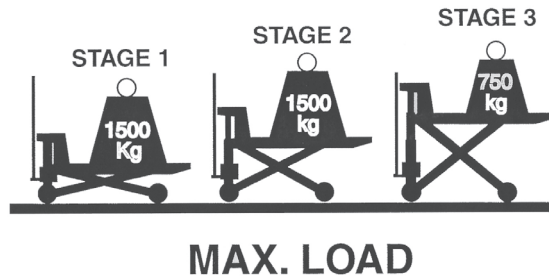

4. Load the truck evenly with the centre of gravity of the load over the centre of the forks. Never stand on the forks.
5. Do not use on rough terrain. The pallet truck is designed for use on smooth flooring only. Do not bounce the truck over rough ground, or down curbs etc. Use ramps wherever possible.
6. Do not move unstable or loosely stacked loads. Use special care when moving long, tall or wide loads or transporting a load which may impair your view.
7. Never position any part of your body under the lifting mechanism or under the forks. Do not transport passengers on the truck.
8. Do not operate a pallet truck until you have checked its condition, giving special attention to the wheels, handle, forks and lift/lower controls.
9. Never use the pallet truck on a gradient if the load is too heavy to be easily handled by the operator. The truck should not be used by operators who are not physically capable of handling the loaded pallet truck.
10. Do not use if wheels or castors are damaged. Have them replaced immediately.
11. When not in use, always ensure the truck is left where it is not hazard to others. Never leave the truck on a gradient without first securely chocking the wheels.

Please keep these instructions in a safe place for future reference.

ASSEMBLY

After unpacking, it is necessary to remove the screw which passes through the bracket and secures the framework together during transit, as shown in Fig 1.

Note: This screw prevents the framework from separating if the truck is picked up, for instance when loading onto a vehicle for transportation. The screw should therefore be retained for future use.

Attach the handle assembly as follows:

1. Lower the chain through the hole in the handle bracket, so that it emerges at the bottom of the housing as shown in Fig 2.
2. Secure the handle to the base bracket with the three socket-headed screws and spring washers provided.
3. Raise the end of the forked lever shown at A (Fig 3), against the spring pressure using a screwdriver or similar, and slide the threaded rod attached to the end of the chain, between the forks, so that the locknut, screwed onto the threaded rod, locates behind the claws on the underside of the forks. Release the forked lever.
4. Remove the travel plug from the oil filler orifice and replace it with the plug arrowed in Fig 4, which is found in the loose polythene bag.

Your pallet truck is now fully assembled. However, before use, it is **IMPORTANT** to check the following adjustments.

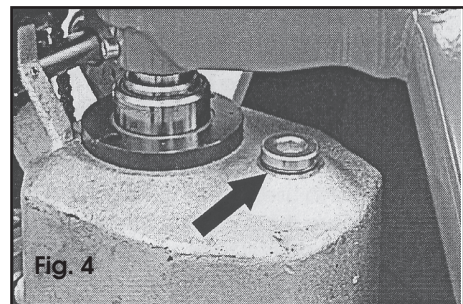
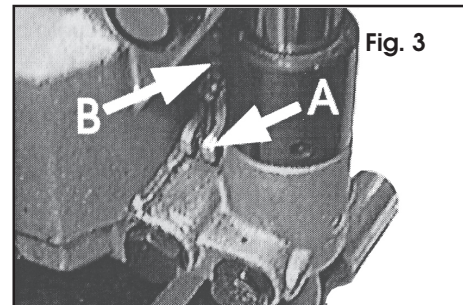
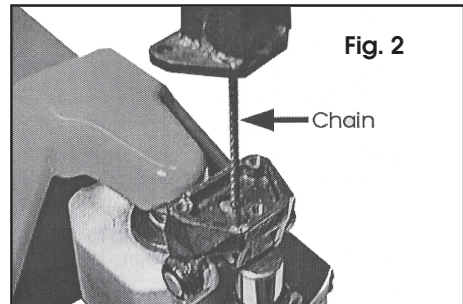

ADJUSTMENT

The control lever has three positions shown in Fig 5 and indicated by the label on the handle.

With the lever pulled to the upper position, the forks will lower.

The middle position allows the load to be transported.

The lower position will cause the forks to lift when the handle is pumped.

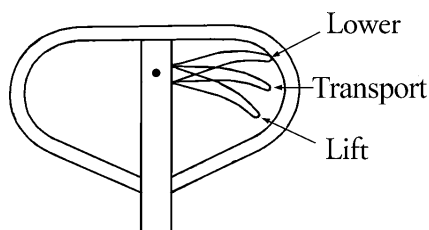

Fig. 5

1. Set the control lever to its lowest position (i.e. Lever in its LIFT position).
2. Check to ensure there is no tension on the chain. If necessary, adjust the locknut on the threaded rod attached to the end of the chain, until the free movement on the end of the control lever, when in its lowest position, is approx 1/4".
3. Pump the handle and then lower to test its operation.
4. If the forks rise but lower immediately you stop pumping or only lift slowly, slacken the locknut 'A' and screw the adjuster 'B' anticlockwise half a turn as shown in Fig 6 and try again.
5. If the forks do not lower when the control handle is in the LOWER position, turn the adjusting screw (A) in clockwise until the handle lowers the forks. Tighten locknut 'B'. Check it's operation in the TRANSPORT position.

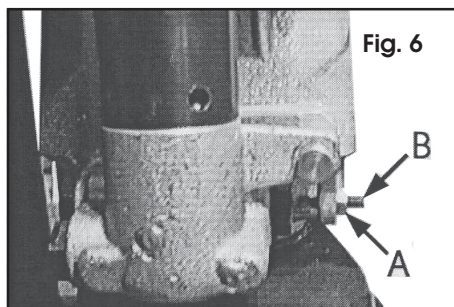

Fig. 6

OPERATION

Before using the pallet truck always read the safety instructions in this manual and the labelling on the product. The rated capacity of the truck assumes an evenly distributed load with it's centre being at the halfway point along the length of the forks.

With the forks in the lowest position, manoeuvre the truck so that it is adjacent to the pallet. Ensure the length of the forks match the length of the pallet.

Always position the pallet truck carefully, ensuring the load is centred about

the forks and is completely stable. Ensure there is no obstruction before raising the load, or that the load cannot foul the truck mechanism when raised.

Lower the forks to the lowest height when the truck is not being used.

When lowering the truck with the forks loaded, pull the control lever up carefully and gradually so that the load descends under complete control.

MAINTENANCE

Whilst the pallet truck requires very little maintenance, the following care can be expected.

DAILY CHECK

Before use, check that there are no foreign bodies such as threads or rag to jam the wheels. Always leave the forks in the lowered position when work is over for the day.

CHECKING THE OIL

Check the oil level every six months by topping up if necessary at the filler plug. The recommended type is L-HV46 Hydraulic oil, provided the truck is not to be used outside the temperature range of -20°C to +40°C.

BLEEDING AIR FROM THE PUMP UNIT

If the pallet truck has to be transported over any distance or been overturned at any time, air may have permeated the hydraulic oil. This will make it impossible to raise the forks under any load when pumping.

To bleed off the air, move the control handle to the lower position, then move the handle up and down several times.

SPECIFICATIONS

Feature	HLPT550	HLPT685
Maximum capacity	1500 kg	1500 kg
Weight	100 kg	110 kg
Width to outside of forks	550 mm	685 mm
Fork length	1150 mm	1150 mm
Fork width	160 mm	160 mm
Gap between forks	230 mm	365 mm
Entry options	4	2
Lifting height (max/min)	85 - 820 mm	85 - 820 mm

TROUBLESHOOTING

Problem	Cause	Action
Forks cannot raise to the maximum height.	Insufficient hydraulic oil.	Top up with oil.
Forks will not raise.	Lack of hydraulic oil. Oil is contaminated. Pumping valve is open due to the nut being too high or the screw is too tight. Air present in the oil.	Top up the oil. Change the oil. Adjust the nut or the screw. Bleed the oil to dispell the air.
Forks cannot be lowered.	Piston rod or pump body is damaged due to uneven loading, overloading or leaning to one side. Fork has been in high position for long enough for corrosion of the exposed piston to occur. Adjusting nut or the screw is not in the correct position.	Replace piston rod or the pump body. Always keep the forks in the lowest position when the truck is not in use. Lubricate the piston rod with oil. Adjust the nut or the screw.
Mechanism is leaking.	Worn or damaged seals.	Overhaul & replace with new parts.
The forks raise but the release valve will not work.	Contamination of the oil is preventing the valve from locking closed. Cracking or wear of the components. Air present in the oil. Oil seals worn or damaged. Adjusting nut or the screw is not in the correct position.	Renew the oil. Inspect parts for wear & replace as necessary. Bleed system to expel the air. Replace worn or damaged seals. Adjust the position of nut or screw.

For parts & servicing, please contact your nearest dealer, or
CLARKE International, on one of the following numbers.

PARTS & SERVICE TEL: 020 8988 7400

PARTS & SERVICE FAX: 020 8558 3622

or e-mail as follows:

PARTS: Parts@clarkeinternational.com

SERVICE: Service@clarkeinternational.com

PARTS LIST & DIAGRAM - PUMP

Ref	Description	Part No
1	Dust Ring	ZJ55001
2	O-Ring	ZJ55002
3	Cylinder	ZJ55003
4	O-Ring	ZJ55004
5	Screw	ZJ55005
6	Washer	ZJ55006
7	Plunger	ZJ55007
8	O-Ring	ZJ55008
9	Mandrell	ZJ55009
10	Spring	ZJ55010
11	Plunger	ZJ55011
12	O-ring	ZJ55012
13	Shaft	ZJ55013
14	Pressure Frame	ZJ55014
15	Pin	ZJ55015
16	Bush	ZJ55016
17	Roller	ZJ55017
18	Pin	ZJ55018
19	Bush	ZJ55019
20	Shaft	ZJ55020
21	Pin	ZJ55021
22	Screw	ZJ55022
23	Washer	ZJ55023
24	Screw	ZJ55024
25	Spring	ZJ55025
26	Spring Seat	ZJ55026
27	Steel Ball	ZJ55027
28	Steel Ball	ZJ55028
29	Valve Seat	ZJ55029

Ref	Description	Part No
30	Valve Seat	ZJ55030
31	Valve Spindle	ZJ55031
32	Spring	ZJ55032
33	Washer	ZJ55033
34	Screw	ZJ55034
35	Steel Ball	ZJ55035
36	Spring	ZJ55036
37	Spring	ZJ55037
38	Pin	ZJ55038
39	Bearing	ZJ55039a
40	Supporting Base	ZJ55040
41	Wheel Housing	ZJ55041
42	Bolt	ZJ55042
43	Nut	ZJ55043
44	Wheel	ZJ55044
45	Bearing	ZJ55045
46	Half Spacer	ZJ55046
47	Washer	ZJ55047
48	Circlip	ZJ55048
49	Dust Cover	ZJ55049
50	O-Ring	ZJ55050
51	Valve Sleeve	ZJ55051
52	O-Ring	ZJ55052
53	Striker Pin	ZJ55053
54	Spring	ZJ55054
55	Adjusting Screw	ZJ55055
56	Nut	ZJ55056
57	Lever Plate	ZJ55057
58	Base	ZJ55058

PARTS LIST & DIAGRAM - PUMP

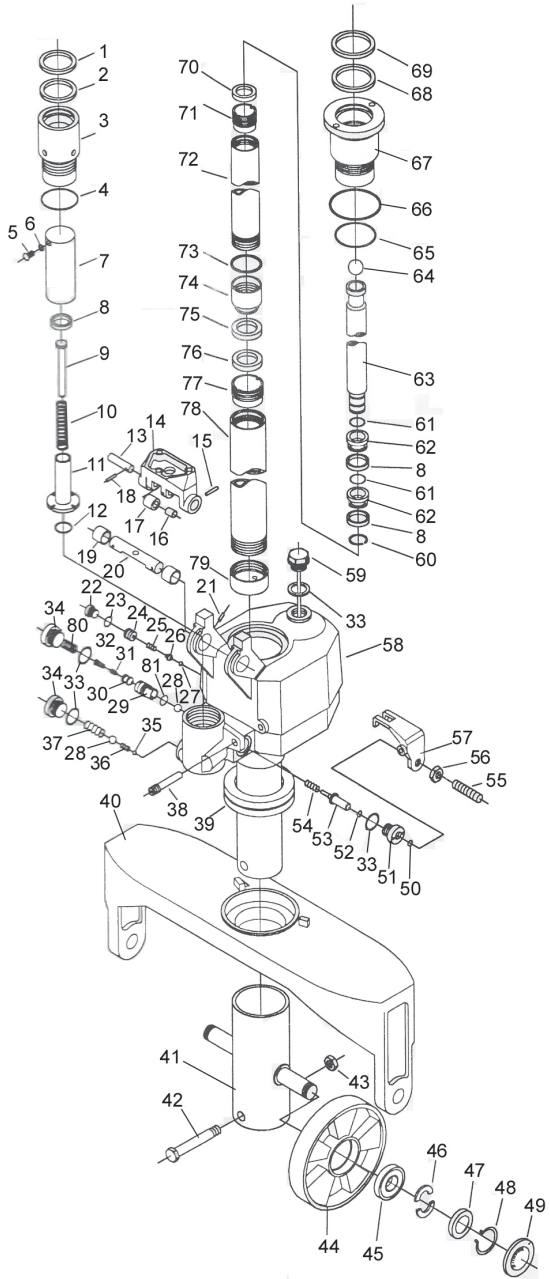

PARTS LIST & DIAGRAM - FORK FRAME

No	Description	Part Ref
59	Oil Filler Cap	ZJ55059
60	Circlip	ZJ55060
61	Washer	ZJ55061
62	Bush	ZJ55062
63	Piston Rod	ZJ55063
64	Steel ball	ZJ55064
65	O-Ring	ZJ55065
66	O-Ring	ZJ55066
67	Cylinder Liner	ZJ55067
68	Sealing Ring	ZJ55068
69	Dust Ring	ZJ55069

Ref	Description	Part No
70	Dust Ring	ZJ55070
71	Bush	ZJ55071
72	Cylinder	ZJ55072
73	O-Ring	ZJ55073
74	Bush	ZJ55074
75	Seal	ZJ55075
76	Dust Ring	ZJ55076
77	Plug	ZJ55077
78	Cylinder Tube	ZJ55078
79	End Cap	ZJ55079
80	Insert	ZJ55080

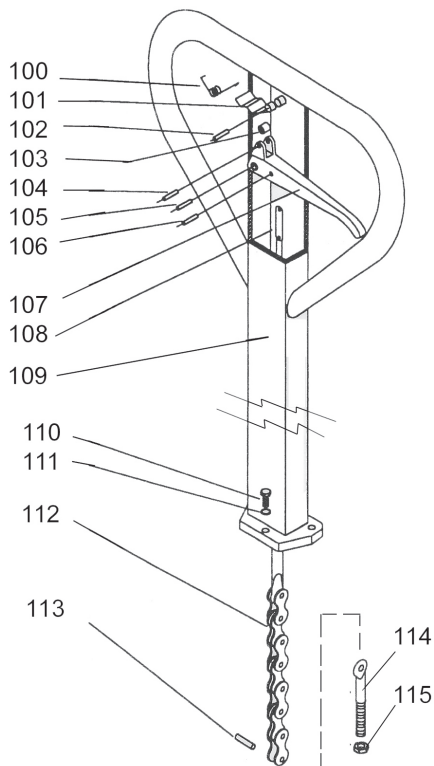

No	Description	Part Ref
100	Spring	ZJ550100
101	Spring Blade	ZJ550101
102	Roller	ZJ550102
103	Roll Pin	ZJ550103
104	Roll Pin	ZJ550104
105	Roll Pin	ZJ550105
106	Roll Pin	ZJ550106
107	Control Handle	ZJ550107
108	Pull Rod	ZJ550108
109	Handle Column	ZJ550109
110	Screw	ZJ550110
111	Lock Washer	ZJ550111
112	Chain	ZJ550112
113	Securing Pin	ZJ550113
114	Adjusting Screw	ZJ550114
115	Nut	ZJ550115

DECLARATION OF CONFORMITY

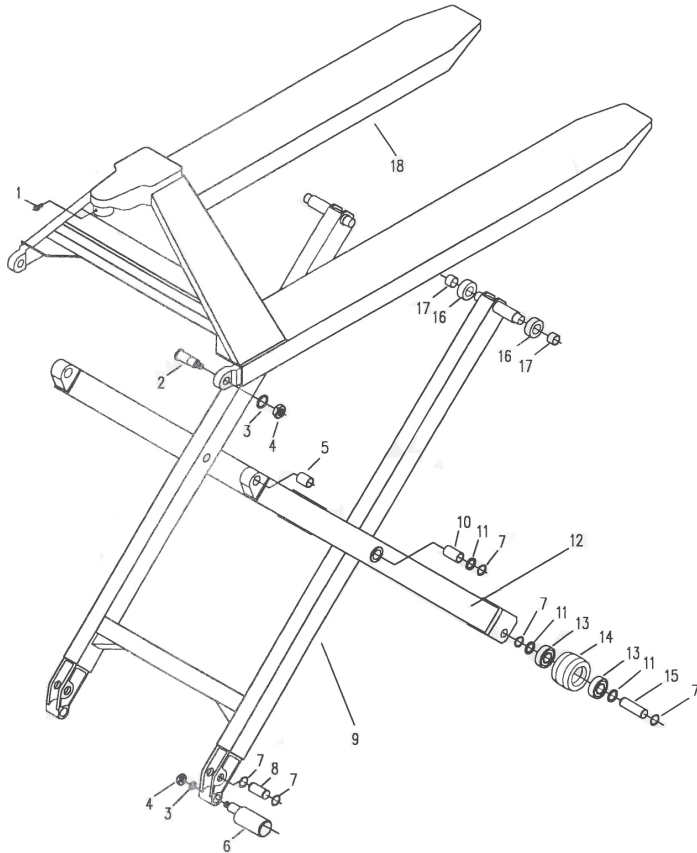

No	Description	Part Ref
1	Screw	ZJ55080
2	Bolt	ZJ55081
3	Washer	ZJ55082
4	Nut	ZJ55083
5	Bush	ZJ55084
6	Foot	ZJ55085
7	Circlip	ZJ55086
8	Pin	ZJ55087
9	Prop Arm	ZJ55088

Ref	Description	Part No
10	Bush	ZJ55089
11	Washer	ZJ55090
12	Support Arm	ZJ55091
13	Bearing	ZJ55092
14	Wheel	ZJ55093
15	Spindle	ZJ55094
16	Roller	ZJ55095
17	Bush	ZJ55096
18	Fork Frame	ZJ55097

A SELECTION FROM THE VAST RANGE OF

Clarke®

QUALITY PRODUCTS

AIR COMPRESSORS

From DIY to industrial, Plus air tools, spray guns and accessories.

GENERATORS

Prime duty or emergency standby for business, home and leisure.

POWER WASHERS

Hot and cold, electric and engine driven - we have what you need

WELDERS

Mig, Arc, Tig and Spot. From DIY to auto/industrial.

METALWORKING

Drills, grinders and saws for DIY and professional use.

WOODWORKING

Saws, sanders, lathes, mortisers and dust extraction.

HYDRAULICS

Cranes, body repair kits, transmission jacks for all types of workshop use.

WATER PUMPS

Submersible, electric and engine driven for DIY, agriculture and industry.

POWER TOOLS

Angle grinders, cordless drill sets, saws and sanders.

STARTERS/CHARGERS

All sizes for car and commercial use.

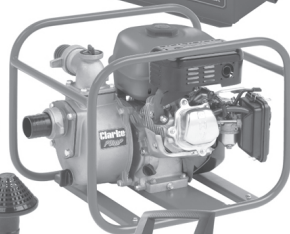
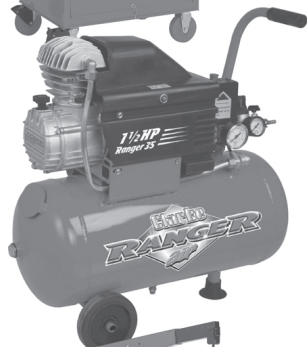

PARTS & SERVICE: 0208 988 7400

E-mail: Parts@clarkeinternational.com or Service@clarkeinternational.com

SALES: UK 01992 565333 or Export 00 44 (0)1992 565335

Clarke® INTERNATIONAL Hemnall Street, Epping, Essex CM16 4LG
www.clarkeinternational.com